

Analysis the Fault Detection under Constraint of Command

Mohssen fisli^{#1}, Said Benagoune^{*2},Tahar Bahi^{#3}

^{#1, 2}Electrotechnical Department, BatnaUniversity, Batna, Algeria

¹m.fisli@hotmail.com

²s_benagoune@yahoo.fr

^{#3}Electrotechnical Department, Annaba University, Annaba, Algeria

³tbahi@hotmail.com

Abstract— This paper presents an analysis of the fault diagnosis of induction machine operating at variable speeds. It is to predict the behaviour and the effectiveness of the diagnostic approach adopted in the closed loop system under the constraint of the speed machine strategy control. A multi-turn model is applied to the defect detection, and a fuzzy logic controller is considered for the variable speed control system. The simulation results are presented and discussed.

Keywords— Diagnosis, impact default, induction machine, closed loop, simulation.

I. INTRODUCTION

In the purview of variable speed drives, induction motors (IM) are supplied with variable amplitude and frequency. In addition, they are expected to operate in a closed loop to ensure desired performance. However, this control structure modifies the behaviour of supervision designed to detect and diagnose any fault of the machine [1].

Indeed, some defects may be masked by the control technology used. Therefore, the diagnostic procedure should be sensitive to possible faults. Remember that the machine cage induction principle diagnostic technique is often based on the analysis of current signatures. To this end, several procedures for the detection and classification of defects are developed for a constant speed function [2]. In this case, the abnormal components which are introduced by a specific defect in the current spectrum is verified and the diagnostic procedure is able to correlate the magnitude of this component with the type of fault.

Now, as for closed loop control, the control automatically changes the behaviour, characteristic indices indicating a fault may not be detected. Therefore, this work studies the influence of the control technology used on the system behaviour and focus on the technique adopted fault diagnosis of broken rotor bar. We considered an extension of the dynamic behaviour of a simple state model. This model allows us to consider the impact of dynamic simulation controls on the process of fault detection. Frequencies specific defects breaks bars obtained using MatLab Simulink software spectrum are taken and analysed.

II. CONTROL OF INDUCTION MACHINES

With vector control [3], the control of an asynchronous machine allows control of torque, speed or even position. As a result, the most control is the primary current and therefore torque [4]. Once the torque control is achieved, one can add a control loop for external speed control. This is known as cascade control; loops are nested in one another. The output of the speed controller is the torque. This reference torque must in turn be imposed by the application of current; it is the role of regulators currents. Vector control [5] is a solution for the decoupling of the flow inside the machine torque developed. Torque transient is expressed in the dq reference as the cross product of currents or flux is:

$$c_e = P \frac{M}{L_r} (\phi_{dr} i_{qs} - \phi_{qr} i_{ds}) \quad (1)$$

While the elimination of the second product ($\phi_{qr} i_{ds}$) can be an expression of the strong torque resembling that of direct current machine (DCM). It suffices to do this, guide the dq references as to cancel the flux component in quadrature. That is to say, to choose the proper rotation angle Park so that the rotor flux is entirely focused on the direct axis(d), as shown in Fig. 1 $\phi_{qr} = 0$; and so $\phi_r = \phi_{dr}$.

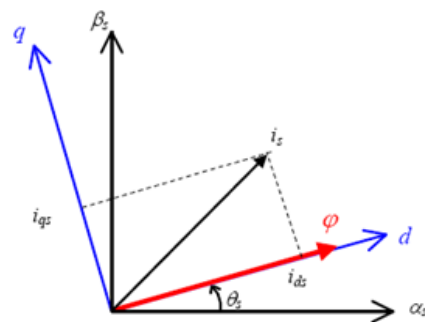

Fig. 1 Principle of vector control

The torque is then written by:

$$c_e = p \frac{M}{L_r} \Phi_r i_{qs} \quad (2)$$

Fig. 2 shows a diagram of vector control of induction motor with speed control and regulation of the two currents i_{ds} and i_{qs} . These two parameters are controlled by two current loops whose outputs are the reference voltages v_{ds}^* and v_{qs}^* in the dq reference.

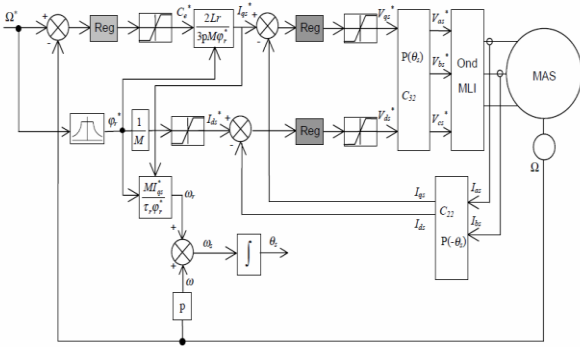

Fig. 2 Schematic of regulating the speed of an IM

III. FUZZY CONTROL

The principle of fuzzy control approaches the human gait in the direction the variables processed are not logical variables but the linguistic variables, near human language. In addition, these linguistic variables are processed using rules that refer to some knowledge of the system behaviour [5].

A series of basic concepts are developed in fuzzy logic. These notions are used to justify and demonstrate some basic principles. In what follows, we will retain only essential to the understanding of the principle of fuzzy logic control elements

The structure of conventional fuzzy control is presented in Fig. 3 [6].

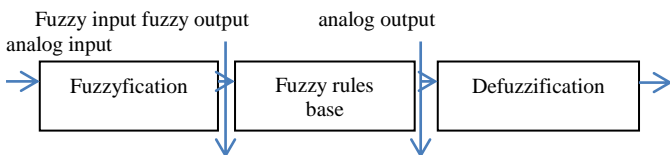

Fig. 3 Block diagram of a fuzzy controller

It is mainly composed of distinct blocks: fuzzification, rules and inferences. The fuzzification transforms variables into deterministic linguistic variables [7]. The rule base characterizes the relations between classes of events possible input and the corresponding controls [5,8]. The inferences that link the measured quantities are the input variables to the output variable [6,9]. The structure of the automated system

may be reduced to a controlled system, whose structure is shown in Fig.4

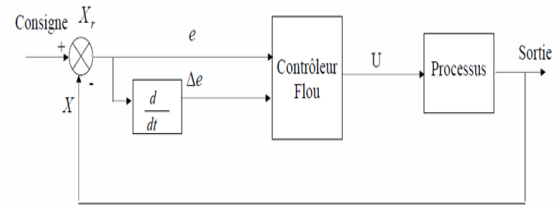

Fig.4 Architecture of the fuzzy control

From the value of the output variable, the fuzzy controller determines the appropriate command to be applied to the process. This is usually calculated for systems with automatic two inputs e and Δe and inference fuzzy rules. In general, e represents the difference between the output signal and the set point of the process.

$$e(K) = X_r(K) - X(K) \quad (3)$$

(Δe) is the variation of the error between the process output and the set point.

$$\Delta e(K) = e(K) - e(K-1) \quad (4)$$

It takes as inputs the controller the error of the rotational speed of an induction machine ($e = \Omega_{ref} - \Omega_r$) and its variation (Δe), and an output torque variation reference electromagnetic (ΔC_{ref}) [10].

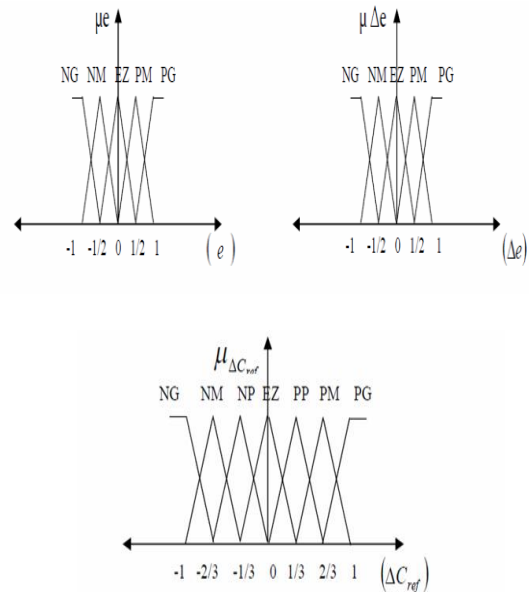

Fig. 5 functioned membership of fuzzy controller

TABLE
INFERENCE TABLE

$e\Delta e$	BN	MN	EZ	MP	BP
BN	BN	MN	SN	SN	EZ
MN	MN	SN	SN	EZ	SP
EZ	SN	SN	EZ	SP	SP
MP	SN	EZ	SP	SP	MP
BP	EZ	SP	SP	MP	BP

The classes are rated as follows: SP: Small Positive ; MP: Medium Positive ; BP : Big Positive ; EZ: Equal to Zero; SN: Small Negative , MP: Medium Negative; BN: Big negative.

Fig.6 can also be applied in the case of the conventional control at the fuzzy logic control.

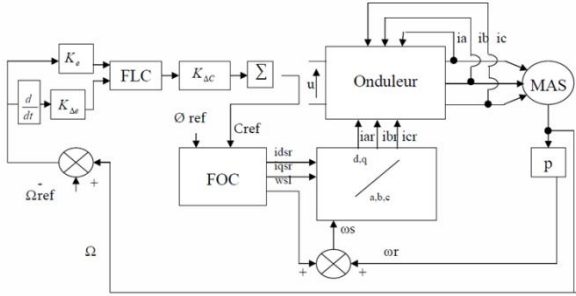

Fig.6 Adjustment structure by a fuzzy PI speed of induction machine

IV. FUZZY PI CONTROLLER APLIED TO THE IM

This law is based on the speed error (e) and its derivative (Δe) as $C=f(e,de)$. Consequently, the activation of all decisions related rule gives variation of the control (ΔC_{ref}) is necessary: allowing the adjustment of such a command. In simple cases, this variation of the order is obtained by a simple reading of a decision table defined off line.

The most general form of the control law is:

$$C_{ref} = C_{ref} + K_{\Delta c} \Delta C_{ref} \quad (5)$$

$K_{\Delta c}$: Normalization gain

ΔC_{ref} : Variation of the command

The error and the derivative of error are adjusted as follows:

$$e = K_e e_n \quad (6)$$

$$\Delta e = K_{\Delta e} \Delta e_n \quad (7)$$

The rules of this controller are systematically constructed based on the study of Vicar-Whelon, can find the table inference anti diagonal classic with a fuzzy system as the input of the error (e) and the derivative (Δe), and as output (ΔC_{ref}) fuzzy fied by seven member ship functions[11]. The rules are presented n table.

V. THE SIMULATION RESULTS

A. Classic Control

Fig. 7 shows the speed setting after the application of the PI control during introduction of a fault-breaking bar at the time $t = 3$ seconds. Fig. 8 and fig. 9 respectively show the currents axes, dq. finally, Fig. 10 shows the spectrum of the stator current, where the frequency of failure of rotor bar breakage are evident.

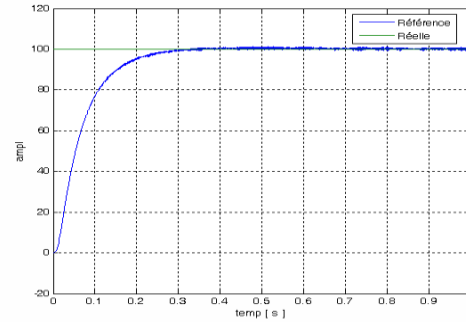

Fig. 7 Speed Response of the machine controlling by PI

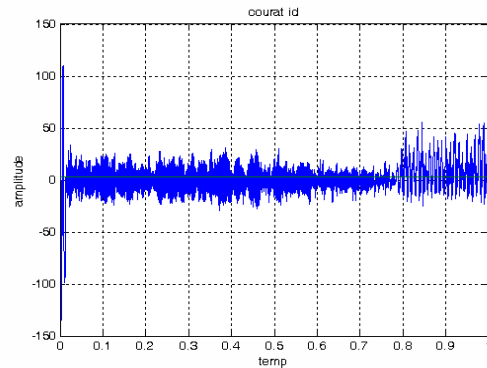

Fig. 8 i_d current of the machine controlling by PI

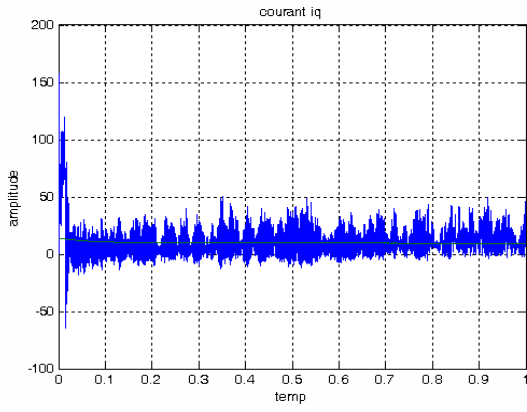

Fig. 9 i_q current of the machine controlling by PI

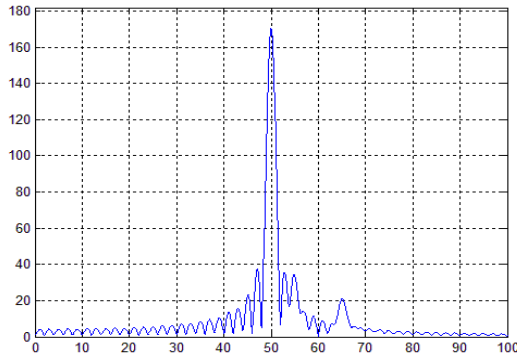

Fig. 10 Stator current spectrum

B. Default under the fuzzy control

Fig.11 shows the dynamic response of the speed of the induction machine in the presence of a fault with the application of the fuzzy control during introduction of a load torque at time $t=3$ s. Fig.12 shows the rotor flux component on the axisq, The pace of Fig. 13 i_{sq} corresponding current to the rotor flux, and Fig.14 shows the spectrum of the stator current, where the frequency of failure of broken rotor bar are clearly.

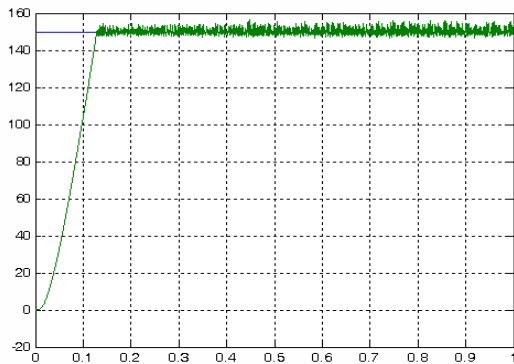

Fig. 11 Speedof the asynchronous machine with the application of the fuzzy control

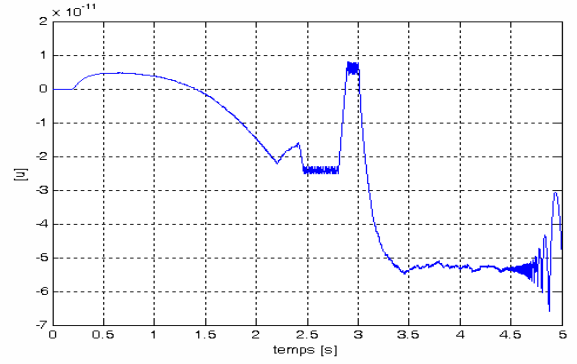

FIG. 12 The rotor flux component on the q axis

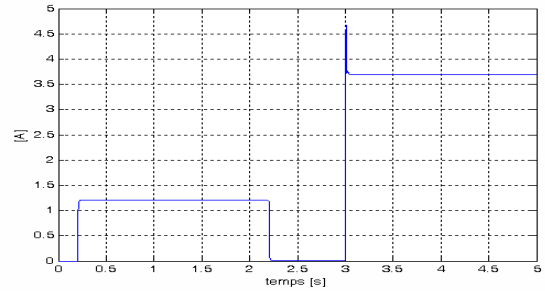

Fig. 13 Allure i_{sq} current corresponding to the rotor flux

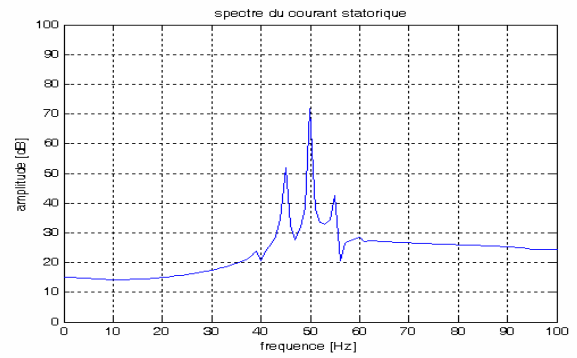

Fig. 14 Stator current spectrum of a machine with broken rotor bar

VI. CONCLUSIONS

Our work consisted primarily to check whether the model adapted by the failure detection is reliable despite the use of robust control (fuzzy control).

The asynchronous machine models healthy functioning and in the presence fault break of the rotor bar have been developed under the effect of the speed control with a classical controller, and then a fuzzy setting, the stator currents are analyzed in the frequency domain. The model dedicated to the detection of the fault remains reliable despite the use of robust tuning.

REFERENCES

- [1] A. Bellini, C. Concari, G. Franceschini, and C. Tassoni, "Diagnosis of Rotor Fault in Closed Loop Induction Motors Drives". Antaba, May 2007.
- [2] MJLH. Benbonzid Bifetigrafy on had "Motors Faults and Diagnosis". *WEE Trans on EC* Vo.14, No.4, Dec. 99, pp. 1065-1074.
- [3] Blaschke, F "The principle of field orientation as applied to the new transvektor closed-loop control system for rotating-field machines" *Siemens Review*, n°5, pp.17-220, 1972.
- [4] B.B. Meunie and comarsal "Logique floue : principe, aide à la décision" Edition Hermes science, lavoisier 2003.
- [5] A.Kaufmann "Introduction à la théories des sous ensemble flous à l'usage des ingénieurs" Tome 1 Edition Mascon, Paris, New york, Barcelone, Milon ,1977.
- [6] T.Takagi and N. Sugeno "Fuzzy identification of systems and its applications to modelling and control" IEEE trans, on systems man and cybernetics, vol .SMC -15pp.116-132, 1985.
- [7] A.Kaufmann "Les logiques humaines et artificielle" Edition hermes ,paris ,1988.
- [8] Pai. A ,D,Umanand ,L,Ra ;N.J "Direct torque control of induction motor with extendedKalman filter" power electronics and motion control conference ,2000 proceeding PIEMC2000,volume :1page :132-137 vol.1[15-18aug2000]
- [9] H. Buhler " Réglage par logique floue ", presses polytechnique et université romande 1994 paris .
- [10] D. Dubis ,H.Parade " Fuzzy sets and systems ,theory and applications ",Academic press1980.
- [11] B. Bouchon .Meunier " La logique floue et ses applications " Edition Addison .wesley, France, décembre 1994.